



The EQE SUV

Price list from 1st January to 31st March Production

MERCEDES-EQ



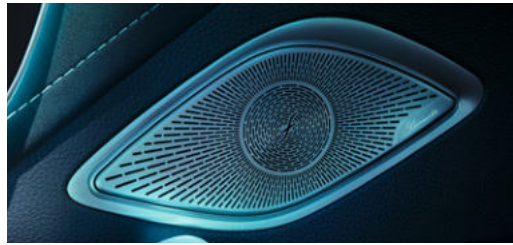



Some of the model features, optional extras and colours shown may not be available, or may only be available in a different specification, or at a different price.

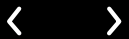

Some of the model features, optional extras and colours shown may not be available, or may only be available in a different specification, or at a different price.

< >

EQE SUV

Technology



Digital Extras Stay connected any time, anywhere.

Mercedes *me*

Mercedes me is a range of innovative online services designed to enhance your Mercedes-Benz experience. Accessible via mobile, tablet or PC, Mercedes me lets you enjoy the highest standards of care and support, in a way that integrates seamlessly with your busy lifestyle.

Safety and Service – Mercedes me connect helps to keep you and your car safe

Check your car's washer fluid level, tyre pressure and battery level from your phone so you'll be ready for every journey.



¹Available on all models with the Vehicle Monitoring package. This option may vary between standard and additional cost dependent on the model

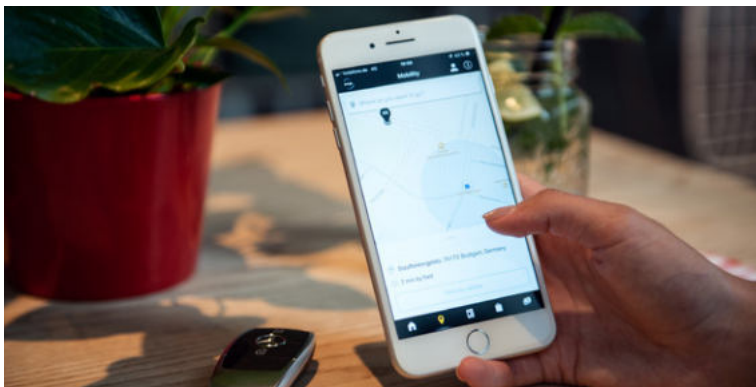

Live Traffic Information, Parked Vehicle Locator and much more with Mercedes me connect

Forgot where you've parked? Parked Vehicle Locator¹ will show you exactly where your car is as long as you're in a 1.5 km radius of where you parked. Real-time traffic data and dynamic route with shorter journey times.

²Part of the Vehicle Status package. This option may vary between standard and additional cost dependent on the model

Comfort – connect to your car anytime, anywhere

Forgot to lock your car? With Remote Car Lock² you will receive a notification on your smartphone to let you know. With one tap, you can lock and unlock your vehicle so you never have to worry.

EQ-specific Services

Check your charging status on the go and programme your pre-entry climate control and charging settings remotely. The EQ-specific navigation considers electrical range, topography and charging stations.

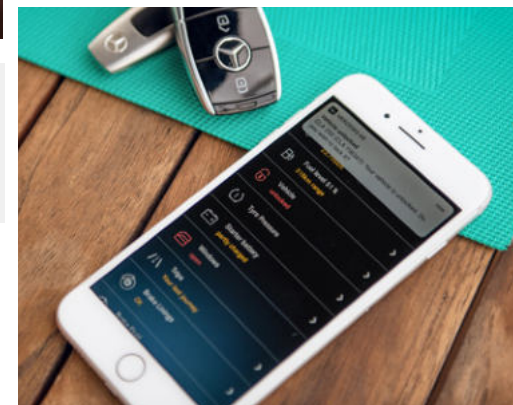

Images shown are for illustration purposes only

Mercedes-Benz User Experience (MBUX)

Transforming the in-car user experience, thanks to MBUX: Controlled via voice, touch or gesture (where fitted) input, the innovative infotainment system can over time even predict personal habits thanks to artificial intelligence.

Voice control

- Activated by the keywords “Hey Mercedes”, the new intelligent voice control LINGUATRONIC¹ lets you control many of the infotainment functions, including destination input, phone calls or music selection
- MBUX is able to understand different accents and will adjust to you over time
- MBUX even understands indirect commands. Feeling chilly? Just say “I feel cold” and MBUX will adjust the temperature for you
- MBUX is able to understand which individual seat the request has come from, and will therefore only respond to their specific request (e.g. adjusting the temperature for just the front passenger)

Touch inputs

- Beside voice control you can operate MBUX via touchscreen, the touch controls on the centre console, as well as touch control buttons on the steering wheel

Personalisation

- Turn the new EQE SUV into your very own Mercedes-Benz by personalising driving modes, radio stations, ambient lighting and much more
- Your personal settings can be saved in up to seven different profiles, making your driving experience the best one possible
- Thanks to artificial intelligence, MBUX is able to learn and adapt over time. It will be able to predict your personal habits, such as navigation for frequently-driven routes, or the radio station you like to listen to on your way home from work

Maintenance and service

- Wondering when the next service is due? Or how much further you can drive until you need to stop at a charging station? Just ask your MBUX – it will tell you the answer



MBUX multimedia system

¹LINGUATRONIC off-board functions are currently only available for three years



EQE SUV

Safety

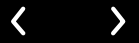

DIGITAL LIGHT

High-definition headlamps with innovative features

The new innovative DIGITAL LIGHT headlamps works like a projector with more than one million pixels per headlamp and responds with brilliant light to changing traffic, road or weather conditions. Its ULTRA RANGE Highbeam with 650 m makes you feel like driving at daylight.

Available as an optional extra or part of Premium Package or Premium Plus Package



Driving Assistance package Plus Cares for what matters.

The EQE SUV comes with standard ground-breaking innovations in safety, comfort and driving functions, to help you stay safe on the road.

Driving Assistance package Plus¹ (code P20) – designed and priced as a package **Standard on Premium and Premium Plus packages**

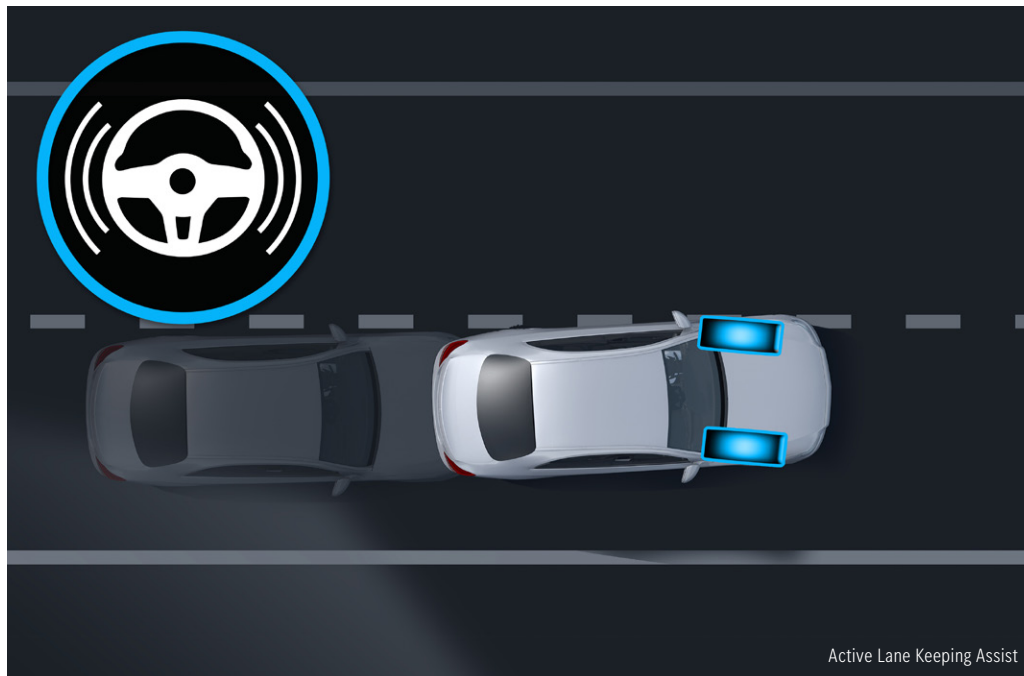

Active Blind Spot Assist expanded with blind spot monitoring towards the front and side. Additional hazard indication of the blind spot warning system as well as exit warning function

Active Brake Assist with cross-traffic function with turning manoeuvre function (responding to (among other things) crossing pedestrians when making a turn). Operating range on urban routes expanded to 120 km/h (previously 70km/h)

Active Distance Assist DISTRONIC responds to stationary road users to prevent collisions up to 130km/h (previously 60 km/h)

Active Emergency Stop Assist: able to assist in manual mode (previously on in DISTRONIC mode). Optional lane change by one lane (at 80 km/h where no obstacles detected)

Active Evasive Steering Assist: responds to cyclists and ends of tailbacks in addition to pedestrians. Operating range on urban routes expanded to 110 km/h (previously 70 km/h)

Active Lane Keeping Assist with enhanced comfort thanks to active steering intervention (instead of braking intervention) and additional hazard indication

Active Speed Limit Assist ensures detected speed limits are automatically adopted as the set speed for Active Distance Assist DISTRONIC

Active Traffic Sign Assist

Congestion emergency braking function

Emergency corridor function

Exit warning function when hand moves towards the door handles

Extended automatic restart on motorways

Hazard display via ambience lighting

Increased availability and cornering performance on carriageways with **Active Steering Assist**, more stern warnings to put hands on the steering wheel with new capacitive steering wheel

PRE-SAFE® PLUS and Impulse Side with body-raising function: when a rear-end collision threatens, PRE-SAFE® PLUS can initiate preventive measures, including warning following traffic and locking the brakes on standstill

Route-based speed adjustment with end of traffic jam function and Active Stop-and-Go Assist adaption of speed before curves, roundabouts and junctions with end of traffic jam function

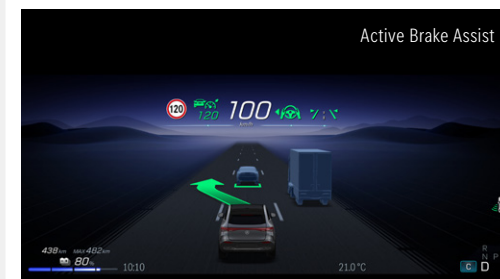

¹Our driver assistance and safety systems are aids and do not relieve you of your responsibility as the driver. Please take note of the information in the Owner's Manual and the system limits which are described therein

< >

EQE SUV

Mercedes-EQ



EQE SUV

MERCEDES-EQ

Vehement power immediately from standstill: An electric motor at the rear axle converts electrical into mechanical energy, and delivers impressive forward thrust. The intelligent operating strategy of the powertrain components supplies the power always wherever it is needed at the moment – efficiently and nearly silently.

EQE 350+

Battery electric vehicle, 292 hp/215 kW
Electric range: up to 605 km/h

EQE 350 4MATIC

Battery electric vehicle, 292 hp/215 kW
Electric range: up to 545 km/h WLTP

EQE 500 4MATIC

Battery electric vehicle, 408 hp/300 kW
Electric range: up to 574 km- WLTP

Mercedes-AMG EQE 53 4MATIC+

Battery electric vehicle, 617 hp/406 kW
Electric range: up to 450 km – WLTP



Standard equipment

AC charging system rated at 11 kW AC for AMG Line

Charging cable for domestic socket, 5 meters

Charging cable for wallbox and public charging stations, Type 2 (Mode 3) – 5 meters

Charging socket

Comfort suspension

DC charging system rated at 170 kW DC

Pre-entry climate control

Radar-based recuperation

Technical details

Electric range¹ 413–605 km

Charging time
Public Rapid charger (170 kW DC) 10–80% 31–32 mins
² Wallbox (11 kW AC) 10–100%³ 10 hrs
Home Wallbox (7.4 kW AC)³ 14 hrs

Range power consumption, combined^{3&4} 224–189 Wh/km

Battery type (capacity) lithium-ion (89–91 kWh)

Capacity on-board charger 11 kW AC; 170 kW DC

Attention

°C Please be aware that external factors such as weather, gradient and ambient temperature amongst others can significantly impact range.



Please also note that internal factors such as driving style and climate control settings etc. can also significantly impact range.



Using the pre-entry climate control when plugged into a charge point will ensure the perfect ambience and ensure that your car is just how you like it, as well as making sure that your battery isn't used unnecessarily to heat/cool the vehicle (maximising range).

1. Figures shown are for comparability purposes; only compare with other cars tested to the same technical procedures. Figures may not reflect real life driving results, which will depend upon a number of factors including the starting charge of the battery, factory-fitted options, accessories fitted (post registration), variations in weather, driving styles and vehicle load. 2. Specified voltage and current values refer to network infrastructure and can be limited by the vehicle. Times are from 10–80% charge using public rapid charging at 170 kW. 3. Specified voltage and current values refer to network infrastructure and can be limited by the vehicle. Times are from 10–100% charge using a wallbox (three-phase) or standard socket (single-phase). 4. Specified voltage and current values refer to network infrastructure and can be limited by the vehicle.

Price List

Electric drive

Model Description	WLTP Table	VRT Band %	Road Tax	kW	BHP	WLTP Range KM	Retail Price
EQE 300 SUV Electric Art	0 - 50	7.0%	€120	180	245	573 km	€99,990
EQE 300 SUV AMG Line	0 - 50	7.0%	€120	180	245	575 km	€108,452
EQE 350 4MATIC SUV Electric Art	0 - 50	7.0%	€120	215	292	553 km	€104,280
EQE 350 4MATIC SUV AMG Line	0 - 50	7.0%	€120	215	292	553 km	€112,742
EQE 350+ SUV Electric Art	0 - 50	7.0%	€120	215	292	614 km	€101,175
EQE 350+ SUV AMG Line	0 - 50	7.0%	€120	215	292	614 km	€109,637
EQE 500 4MATIC SUV Electric Art	0 - 50	7.0%	€120	300	408	590 km	€113,400
EQE 500 4MATIC SUV AMG Line	0 - 50	7.0%	€120	300	408	590 km	€121,847
MERCEDES-AMG EQE 43 4MATIC SUV	0 - 50	7.0%	€120	350	476	473 km	€143,010
MERCEDES-AMG EQE 53 4MATIC+ SUV	0 - 50	7.0%	€120	460	625	452 km	€161,500

*Prices applicable to all models registered from 1st January to 31st March 2025 . MY805 +055 stock in the country. Subject to availability. Terms & Conditions apply.

Owing to supply shortages, options for vehicles may be temporarily restricted, resulting in modified vehicle and/or package pricing . Regularly updated information on this issue is available from Mercedes-Benz dealers.

< >

EQE SUV

Model lines overview



Electric Art



AMG Line

EQE SUV Electric Art

Standard exterior equipment highlights



Exterior

19-inch 5-twin-spoke light-alloy wheels painted in tremolite grey (code R55)

AIRMATIC air suspension with adaptive damping system

Electric Art bodystyling

EASY-PACK powered tailgate

LED headlamps with Adaptive Highbeam Assist

Seamless door handles



Subject to vehicle specification and availability

EQE SUV Electric Art

standard interior equipment highlights



Interior

Ambient lighting – with projection of brand logo

Automatically dimming rear view mirror

Electrically adjustable front seats

Heated front & rear seats

Lumbar Support (4-way)

Multifunction sports steering wheel in leather

THERMATIC dual-zone automatic climate control

Subject to vehicle specification and availability

Communications, Safety and Assistance Systems

12.3-inch digital instrument display

12.8-inch media display

Active Parking Assist with PARKTRONIC and reversing camera

Active Distance Assist DISTRONIC

Blind Spot Assist

Smartphone integration¹ including Apple CarPlay® and Android Auto™

Wireless charging¹ in the front centre console

¹Compatible mobile phone required



Trim and Upholstery

Leather – black / space grey

black fine-structure trim



EQE SUV AMG Line exterior equipment highlights (optional extra)



Exterior

20-inch AMG alloy wheels – 5-twin-spoke design, aerodynamically optimised, painted vanadium silver with aero elements in matt tantalite grey (code RRT)

AIRMATIC air suspension with adaptive damping system

AMG bodystyling

EASY-PACK powered tailgate

LED headlamps with Adaptive Highbeam Assist

Seamless door handles



Subject to vehicle specification and availability

EQE SUV AMG Line interior equipment highlights (optional extra)



In Addition to / Replacement of Electric Art Interior....

AMG floor mats

AMG sports pedals in brushed stainless steel

Anthracite open-pore line structure lime wood trim elements

Door centre panels in black MICROCUT microfibre with red topstitching

Door sill panels with "Mercedes-Benz" lettering, illuminated

Roof liner in black fabric

Sport Seats



Trim and Upholstery

Leather – black / space grey

Anthracite open-pore line structure lime wood trim elements



Electric Art Upholsteries

Electric Art Interior - Leather



Black / Space Grey
(201A)(Standard)



Neva Grey / Balao Brown
(209A) (Optional)



Black / Balao Brown
(211A)(Optional)



Neva Grey / Biscay Blue
(219A)(Optional)



Black / Biscay Blue
(221A)(Optional)

Electric Art Interior - Nappa Leather

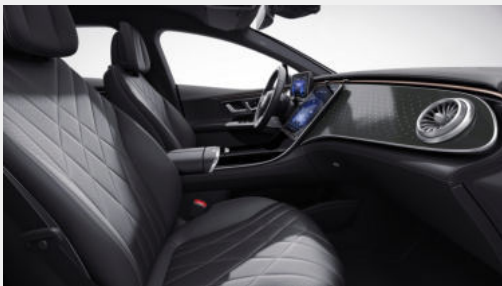

Black / Space Grey
(801A)(Optional)



Balao Brown / Black
(804A)(Optional)



Balao Brown / Neva Grey
(814A)(Optional)



Black / Biscay blue
(821A)(Optional)

AMG Line Upholsteries

AMG Line Interior - Leather



Black/Space Grey (231A)
(Standard)



Neva grey / Biscay blue (249A)
(Optional)

Trim options



Anthracite linestructure lime wood trim (H08)
(Standard)



Ship's deck open-pore walnut wood trim (H39)
(Option)



Laser-cut backlit trim with Mercedes-Benz pattern (51H)
(Option)



Black fine structure-look trim (H51)
(Option)



Brown open-pore magnolia wood trim elements with Mercedes-Benz pattern in aluminium (H20)
(Option)



Anthracite 3D relief-look trim (H67)
(Option)



AMG carbon-fibre trim element (H73)
(Option for Premium package)

Wheel options

19"



R55 (Standard Electric Art Exterior)

5-twin-spoke light-alloy wheels painted in tremolite grey



R17 (Option)

5-twin-spoke light-alloy wheels aerodynamically optimised, painted in vanadium silver with aero elements painted in high-gloss black

20"



RRT (Standard AMG Line)

AMG 5-twin-spoke light-alloy wheels aerodynamically optimised, painted in vanadium silver with aero elements in matt tantalite grey

20"



96R (Option)

5-spoke light-alloy wheels aerodynamically optimised, painted in high-gloss black with a high-shine finish



29R (Option)

5-spoke light alloy wheels aerodynamically optimised, painted in high-gloss black with a high-shine finish



R61 (Option)

5-spoke light-alloy wheels aerodynamically optimised, painted in high-gloss black with a high-shine finish



RRU (Option for AMG Line)

AMG 5-twin-spoke light-alloy wheels aerodynamically optimised, painted in high-gloss black with a high-shine finish

Wheel options

21"



19R(Option)

5-triple-spoke light-alloy wheels aerodynamically optimised, painted in high-gloss black with a high-shine finish



70R(Option)

5-quadruple-spoke light-alloy wheels aerodynamically optimised, painted in high-gloss black with a high-shine finish



RWX(Option)

AMG multi-spoke light-alloy wheels aerodynamically optimised, painted in high-gloss black with a high-shine finish

22"



RPE(Option for AMG Line)

AMG multi-spoke light-alloy wheels aerodynamically optimised, painted in high-gloss black with a high-shine finish

Colour options



197 black non metallic (Standard)

No cost option



149 white non metallic

No Cost option



922 high-tech silver metallic

No cost option



197 obsidian black metallic

No cost option



989 emerald green metallic

No cost option



040 Solid paint black

No cost option



842 sodalite blue metallic

No cost option



992 selenite grey metallic

No cost option



956 MANUFATUR alpine grey

Cost option

Please note that, owing to limitations of on-screen representation, paint colours may differ from those shown

Advanced Plus Package From¹ €1,897

Ambient Lighting: in addition to the standard interior Ambient Lighting...

- Contour lighting of the seats
- Dynamic mode: the colours alternate slowly
- Emotively appealing animations: welcome display or feedback in colour when adjusting the air conditioning
- When plugging in the charging cable, each state of charge is visualised for approx. 30 seconds, similar to the LED in the vehicle socket

Driving Assistance Package Plus: reach your destination relaxed and safe: based on the situation, the assistance systems of this package support you with speed adjustment, observing the required distance, staying in lane and changing lane. The accident risk is reduced – your passengers and other road users are protected effectively.

Illuminated Door Sills with "Mercedes-Benz" Lettering

KEYLESS-GO: puts an end to searches for the vehicle key. As soon as the convenience system detects your key in the immediate vicinity of the vehicle, the flush-fitting door handles automatically extend. When you drive off or lock the doors, they retract and are elegantly integrated into the side design – a clear technical and visual advantage for you.

Memory Package: you can store and select up to 3 different seat positions. In addition, the positions of the steering wheel, exterior mirrors and the optional head-up display are stored.

Stowage Compartment Beneath Centre Console



¹Price and availability subject to vehicle specification

Owing to supply shortages, options for vehicles may be temporarily restricted, resulting in modified vehicle and/or package pricing.

Regularly updated information on this issue is available from Mercedes-Benz dealers.

Premium Package From¹ €6,464

In addition to/replacement of Advanced Plus Package components

Active Ambient Lighting: in addition to the standard interior Ambient Lighting...

High-quality matt-white line as part of the lamellar trim element with a total of approx. 190 integrated and individually controllable LEDs

- Diverse colour moods, also with static or multicolour animated colour worlds
- Driving assistance systems are also included and are supported visually
- Outline of electric driving: drive, recuperation, boost
- Emotively appealing animations: welcome display or feedback in colour when adjusting the air conditioning or interaction with the voice control

DIGITAL LIGHT: you can experience brilliant lighting conditions – constantly adjusted to other road users and to the surroundings. This HD system works like a projector and responds with constantly adapted light to changing traffic, road or weather conditions.

- HD system with projection module (more than 1.3 million pixels per headlamp) and MULTIBEAM LED background module
- With data from the camera, sensors and navigation system, the brightness value for each individual pixel is calculated virtually in real time
- Adaptive Highbeam Assist Plus (anti-dazzle continuous high beam)
- ULTRA RANGE Highbeam with nearly legally permitted maximum headlamp range

MBUX Augmented Reality for Navigation

Parking Package with 360 degree Camera



¹Price and availability subject to vehicle specification

Owing to supply shortages, options for vehicles may be temporarily restricted, resulting in modified vehicle and/or package pricing.

Regularly updated information on this issue is available from Mercedes-Benz dealers.

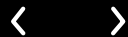

Premium Plus Package From¹ €9,534

In addition to/replacement of Premium Package components.

Burmester 3D Surround Sound System: Experience greater audio performance with exquisite Burmester® sound. The high-quality speakers achieve impressive surround sound. You can specifically optimise this for the front and rear seats to intensify the listening experience. In addition the specially designed Sound Experience reinforces your electric driving experience in the interior.

- 15 high-performance speakers tuned to match the vehicle interior and each with its own amplifier channel
- DSP amplifier with a total output of 710 watts (2 x 120 watts, 7 x 50 watts, 6 x 20 watts)

DIGITAL LIGHT with Projection Function: in addition to Digital Light features...

- Projection function for lines, for example as guide lines in roadworks
- Projection function for symbols, e.g. as a direction symbol for lane correction when departing from the lane
- Projection function for animations, light shows when opening and closing the vehicle

Head-up Display: Ideal prospects for sporty driving pleasure and a superior driving experience: The head-up display transforms your windscreen into a digital cockpit. With the virtual, full-colour image, you always have a direct view of key information. Your full attention remains on the road and the traffic conditions in front of you.

THERMOTRONIC 4 Zone Climate Control

USB Package Plus: Fast power supply for a smartphone or tablet: You and your passengers can conveniently charge mobile devices at a total of 6 USB-C ports. All onboard USB ports also have a fast-charging capability. Using devices connected in the front, you can also feed data such as your stored music into the multimedia system.

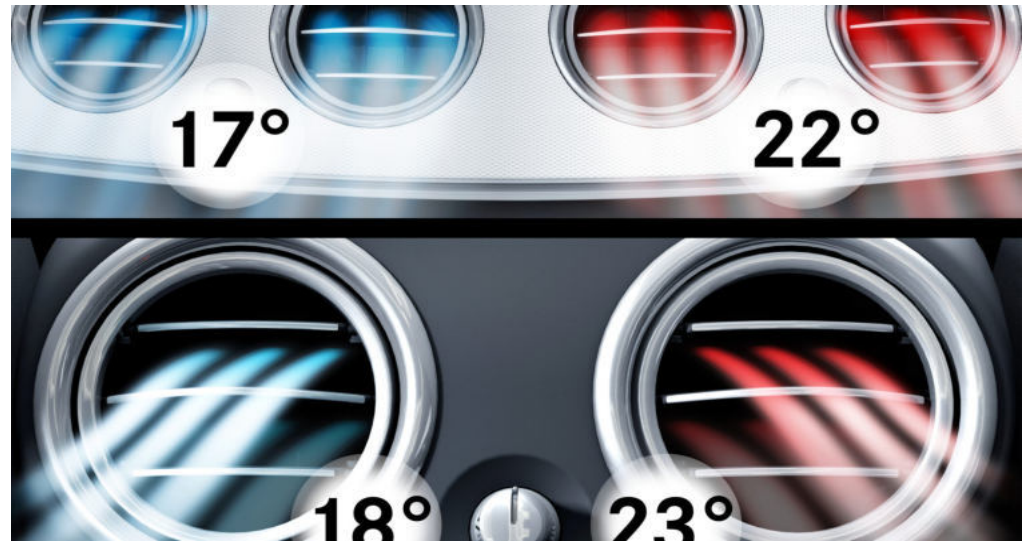

¹Price and availability subject to vehicle specification
 Owing to supply shortages, options for vehicles may be temporarily restricted, resulting in modified vehicle and/or package pricing.
 Regularly updated information on this issue is available from Mercedes-Benz dealers.

Night Package

From¹ €1,581

With the Night Package, your sporty exterior looks even more expressive. In this case, numerous features have a black or black chrome finish. Depending on the paint finish, this creates contrasts or smooth transitions. Regardless of how, it's always a clear plus for your individuality.

Components:

- Outside mirror housings in black
- Beltline and windowline trim strips in black
- Heat-insulating dark tinted glass from the B-pillar to the rear, optional omission of heat-insulating dark tinted glass
- Door trim strips in black chrome

For Electric Art Exterior...

- Front apron trim in black chrome
- Simulated underguard on the rear apron in black chrome

For AMG Line Exterior...

- Trim parts on the A-wing and front splitter in black chrome
- Trim element on the rear apron with two louvres each left and right in black chrome



¹Price and availability subject to vehicle specification

Owing to supply shortages, options for vehicles may be temporarily restricted, resulting in modified vehicle and/or package pricing.

Regularly updated information on this issue is available from Mercedes-Benz dealers.

Towing package

The Towing package offers an electronically folding tow bar which increases the towing capacity up to 3,500 kg.

Towing package (code 550) - designed and priced as a package, including items as listed.

From¹ €1,084

Consisting of:

Control button with LED light in the tailgate

Electrically folding trailer hitch, stows behind the bumper when not in use

Increased towing capacity - max. 3,500 kg

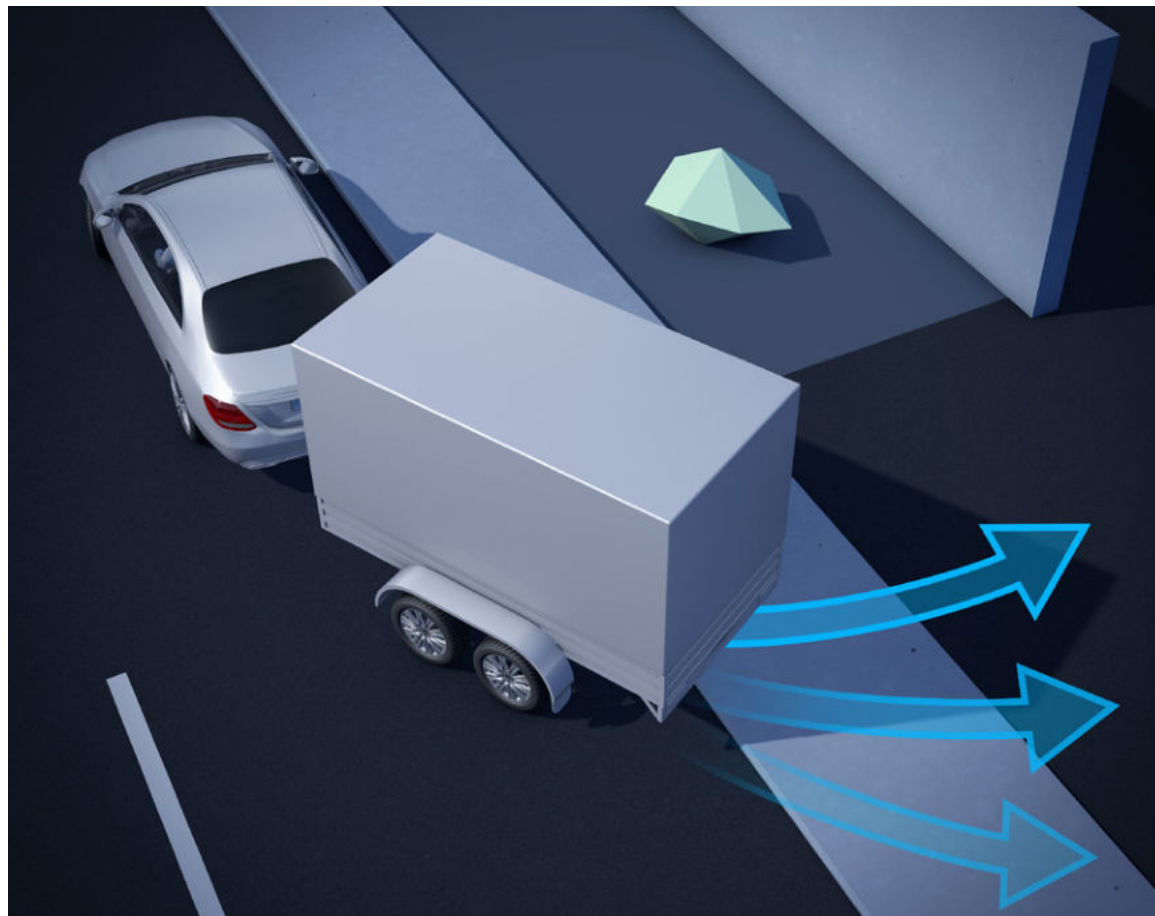

¹Price and availability subject to vehicle specification

Owing to supply shortages, options for vehicles may be temporarily restricted, resulting in modified vehicle and/or package pricing.

Regularly updated information on this issue is available from Mercedes-Benz dealers.

Hyperscreen package

Enhance your interior with an impressive design feature. As if cast from a single mould, three displays seamlessly blend together beneath a glass panel to create one large MBUX hyperscreen. Brilliant OLED technology enhances your display comfort, while the haptic feedback helps to simplify input on the touchscreen.

Hyperscreen package (code PAG)

From¹ €12,413

Consisting of:

12.3-inch OLED display for the front passenger provides them with their very own display and control area

12.3-inch OLED driver's display & 12.8-inch OLED central display

Bright OLED displays with haptic feedback and innovative zero-layer interface

Pre-installation for MBUX Entertainment



¹Price and availability subject to vehicle specification

Owing to supply shortages, options for vehicles may be temporarily restricted, resulting in modified vehicle and/or package pricing.

Regularly updated information on this issue is available from Mercedes-Benz dealers.

EQE SUV

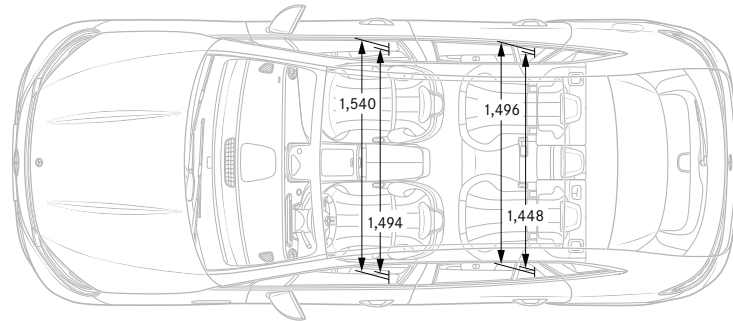
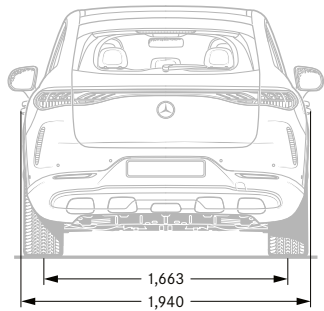
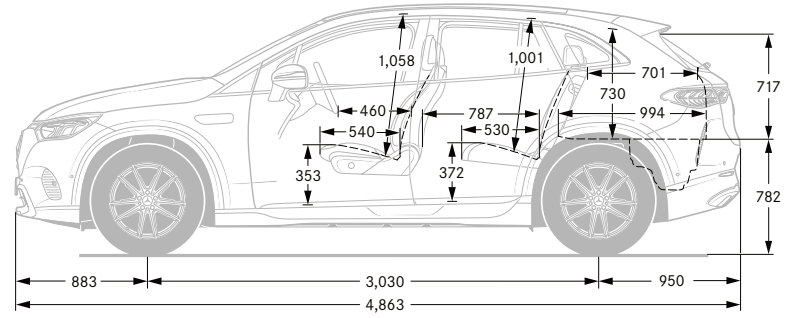
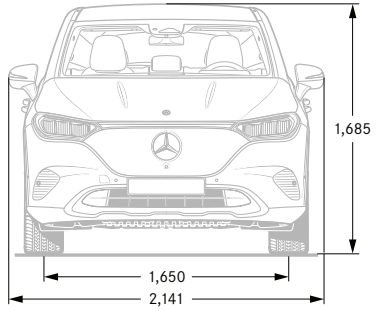

Technical data

- Standard

Model		EQE 350+	EQE 350 4MATIC	EQE 500 4MATIC	Mercedes-AMG EQE 53 4MATIC+
Motor					
Battery type		lithium-ion high-voltage	lithium-ion high-voltage	lithium-ion high-voltage	lithium-ion high-voltage
Electric motor type		asynchronous	asynchronous	asynchronous	asynchronous
Battery capacity	kWh	96	91	96	91
Power ¹	hp (kW)	288 (215)	288 (215)	402 (300)	617 (460)
Torque ¹	Nm at rpm	565/3,559	765/2,662	858/3,337	950/4,639
On-board charger	kW	22 kW AC; 170 kW DC	22 kW AC; 170 kW DC	22 kW AC; 170 kW DC	22 kW AC; 170 kW DC
Emissions standard		Euro 6e	Euro 6e	Euro 6e	Euro 6e

Transmission					
Single-speed automatic		●	●	●	●

Performance					
Acceleration 0–100 km/h	sec	6.9	6.6	5.0	3.7
Top speed	km/h	210	210	210	220
Charging time					
Public Rapid charger (170 kW DC) 10–80% ²		32 mins	32 mins	32 mins	32 mins
Wallbox (22 kW AC) 10–100% ³		5 hrs 15 mins	4 hrs 45 mins	5 hrs 15 mins	4 hrs 45 mins
Home Wallbox (7.4 kW AC) ⁴		15 hrs	14 hrs 15 mins	15 hrs	14 hrs 30 mins
Electric energy consumption, combined ^{4,5}	Wh/km	177–211	183–222	184–222	231–254
Electric range – WLTP ⁴	km	530–627	471–567	505–603	410–435

¹Figures according to Regulation (EC) No. 595/2009 in the currently applicable version ²Specified voltage and current values refer to network infrastructure and can be limited by the vehicle. Times are from 10–80% charge using public rapid charging at 170 kW ³Specified voltage and current values refer to network infrastructure and can be limited by the vehicle. Times are from 10–100% charge using a wallbox (three-phase) or standard socket (single-phase) ⁴Figures shown are for comparability purposes; only compare with other cars tested to the same technical procedures. Figures may not reflect real life driving results, which will depend upon a number of factors including the starting charge of the battery, factory-fitted options, accessories fitted (post registration), variations in weather, driving styles and vehicle load. Further information about the test used to establish range, power consumption and CO₂ figures can be found at <https://www.mercedes-benz.ie/our-brands/e-mobility/> ⁵Specified voltage and current values refer to network infrastructure and can be limited by the vehicle

Mercedes me

Welcome to your Mercedes-Benz world.

Imagine if ...you could connect with your Mercedes-Benz? With Mercedes me connect, you can! Mercedes me connect offers you new connectivity services that make driving more comfortable and incorporates your car into your personal lifestyle.

Standard Services

- Maintenance Management
- Telediagnosics
- Breakdown Management
- Accident Recovery
- Mercedes-Benz Emergency Call System

Remote Online Services¹

- Remote Retrieval of Vehicle Status (fuel level, tyre pressure etc.)
- Parked Vehicle Locator
- Vehicle Tracker
- Geofencing
- Door lock / unlock function

¹ Can be used with Remote Online special feature.





Getting connected is easy. Just set up your Mercedes me account and get in touch with your Mercedes-Benz dealer to connect your vehicle to your profile to access your Mercedes me connect services.

Contact your dealer to get connected, or go to www.mercedes.me for more details.

Follow us on the following social media channels:

 facebook.com/MercedesBenzCarsIreland

 instagram.com/mercedesbenz_cars_ireland

 linkedin.com/company/motor-distributors-ltd

 twitter.com/MercedesBenzIre

 youtube.com/mercedes-benzireland

Motor Distributors Ltd.
Naas Road
Dublin 12
Ireland
www.mercedes-benz.ie

Information correct at time of going to print. Prices and specifications are subject to change without prior notice. Prices quoted do not include dealer and delivery related charges. Images are for illustrative purposes only, actual product may vary. For more specific information in relation to the range of models, features, optional extras, colours and services available please speak to your local authorised Mercedes-Benz dealer.



EQE SUV

EQE SUV