



# The B-Class

Price List as of 1<sup>st</sup> July to 31<sup>st</sup> August 2022

Mercedes-Benz



# Welcome

At Mercedes-Benz we appreciate the importance of detail. Over the following pages you'll find model prices and a breakdown of standard and optional equipment, as well as details of the attractive finance offers and benefits that are available to every Mercedes-Benz driver.

We have highlighted some of the best styling features both inside and out, some of the new technology features and some body styling options which all combine to give you a unique driving experience. To experience a full listing of what is available; please speak directly to your local Mercedes-Benz Dealer.

Of course, some things have to be experienced to be truly appreciated, such as the qualities that set a Mercedes-Benz apart, which is why we'd like to invite you for a test drive at your local Mercedes-Benz Dealership. Discover the location and the contact details of your local Mercedes-Benz Dealership at **[www.mercedes-benz.ie](http://www.mercedes-benz.ie)**





# Price List

## Petrol

| Model Description        | Wheel size | CO2     | VRT Rate | Road Tax | CC   | BHP | Price*  |
|--------------------------|------------|---------|----------|----------|------|-----|---------|
| B 180 A/T Progressive    | 17"        | 136-140 | 20.00%   | €210     | 1332 | 136 | €42,650 |
| B 180 A/T AMG Line       | 18"        | 136-140 | 20.00%   | €210     | 1332 | 136 | €44,893 |
| B 200 A/T Progressive    | 17"        | 136-140 | 20.00%   | €210     | 1332 | 163 | €44,990 |
| B 200 A/T AMG Line       | 18"        | 136-140 | 20.00%   | €210     | 1332 | 163 | €47,233 |
| B 200 4MATIC Progressive | 17"        | 151-155 | 27.50%   | €280     | 1332 | 163 | €57,400 |
| B 200 4MATIC AMG line    | 18"        | 151-155 | 27.50%   | €280     | 1332 | 163 | €59,850 |

## Petrol Plug-In Hybrid

| Model Description  | Wheel size | CO2  | VRT Rate | Road Tax | CC   | BHP | Price*  |
|--|------------|------|----------|----------|------|-----|---------|
| B 250 e Progressive  | 17"        | 0-50 | 7.00%    | €140     | 1332 | **  | €51,420 |
| B 250 e AMG Line   | 18"        | 0-50 | 7.00%    | €140     | 1332 | **  | €53,905 |
| ** 1,332cc, 4-cylinder, 160hp - Electric Motor 102hp. System Output 218hp. |            |      |          |          |      |     |         |

\*Prices applicable to all models registered from 01st July to 31st August 2022 . Subject to availability. Terms & Conditions apply. Prices quoted do not include dealer and delivery related charges.

Owing to supply shortages, options for vehicles may be temporarily restricted, resulting in modified vehicle and/or package pricing . Regularly updated information on this issue is available from Mercedes-Benz dealers.

# Price List

## Diesel

| Model Description          | Wheel size | CO2     | VRT Rate | Road Tax | CC   | BHP | Price*  |
|----------------------------|------------|---------|----------|----------|------|-----|---------|
| B 180 d A/T Progressive    | 17"        | 136-140 | 20.00%   | €210     | 1950 | 116 | €45,045 |
| B 180 d A/T AMG Line       | 18"        | 136-140 | 20.00%   | €210     | 1950 | 116 | €47,288 |
| B 200 d A/T Progressive    | 17"        | 131-135 | 19.25%   | €210     | 1950 | 150 | €45,895 |
| B 200 d A/T AMG Line       | 18"        | 131-135 | 19.25%   | €210     | 1950 | 150 | €48,119 |
| B 220 d A/T Progressive    | 17"        | 131-135 | 19.25%   | €210     | 1950 | 190 | €48,810 |
| B 220 d A/T AMG Line       | 18"        | 131-135 | 19.25%   | €210     | 1950 | 190 | €51,034 |
| B 220 d 4MATIC Progressive | 17"        | 136-140 | 20.00%   | €210     | 1950 | 190 | €51,480 |
| B 220 d 4MATIC AMG Line    | 18"        | 136-140 | 20.00%   | €210     | 1950 | 190 | €53,723 |

\*Prices applicable to all models registered from 01st July to 31st August 2022 . Subject to availability. Terms & Conditions apply. Prices quoted do not include dealer and delivery related charges.

Owing to supply shortages, options for vehicles may be temporarily restricted, resulting in modified vehicle and/or package pricing . Regularly updated information on this issue is available from Mercedes-Benz dealers.



B-Class

---

# Technology

# Mercedes-Benz User Experience (MBUX)

Transforming the in-car user experience, thanks to MBUX: Controlled via voice or touch input, the innovative infotainment system can over time even predict personal habits thanks to artificial intelligence.

Multi-gesture touchpad control



MBUX multimedia system with DAB digital radio



## Voice control

- Activated by the keywords “Hey Mercedes”, the new intelligent voice control LINGUATRONIC<sup>1</sup> lets you control many of the infotainment functions, including destination input, phone calls or music selection
- MBUX is able to understand different accents and will adjust to you over time
- MBUX even understands indirect commands. Feeling chilly? Just say “I feel cold” and MBUX will adjust the temperature for you

## Touch inputs

- Beside voice control you can operate MBUX via touchscreen, the touchpad on the centre console, as well as touch control buttons on the steering wheel
- The touchpad recognises your handwriting should you wish to enter addresses or phone numbers silently

## Personalisation

- Turn the B-Class into your very own Mercedes-Benz by personalising driving modes, radio stations and much more
- Your personal settings can be saved in up to seven different profiles, making your driving experience the best one possible
- Thanks to artificial intelligence, MBUX is able to learn and adapt over time. It will be able to predict your personal habits, such as navigation for frequently-driven routes, or the radio station you like to listen to on your way home from work

## Maintenance and service

- Wondering when the next service is due? Or how much further you can drive until you need to stop at a petrol station? Just ask your MBUX – it will tell you the answer

<sup>1</sup>LINGUATRONIC off-board functions are currently only available for three years



# Mercedes me connect

Stay connected any time, anywhere.

Mercedes *me*

Mercedes me is a range of innovative online services designed to enhance your Mercedes-Benz experience. Accessible via mobile, tablet or PC, Mercedes me lets you enjoy the highest standards of care and support, in a way that integrates seamlessly with your busy lifestyle.

## Safety and Service – Mercedes me connect helps to keep you and your car safe

Check your car's oil level, tyre pressure and fuel from your phone so you'll be ready for every journey.

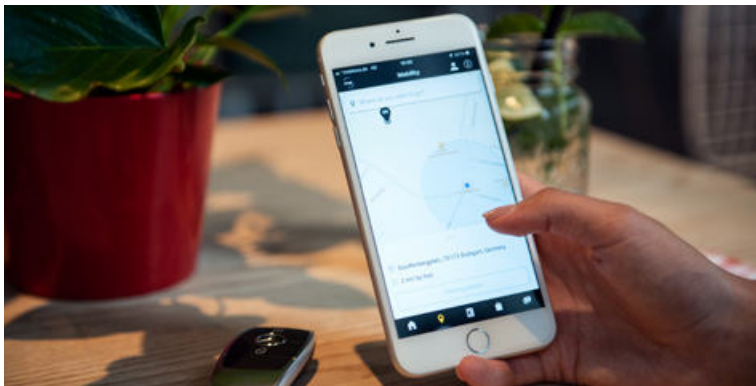

## Live Traffic Information, Parked Vehicle Locator and much more with Mercedes me connect

Forgot where you've parked? Parked Vehicle Locator<sup>1</sup> will show you exactly where your car is as long as you're in a 1.5km radius of where you parked. Real-time traffic data and dynamic route with shorter journey times.

For more information speak to your local Retailer or visit the Mercedes me connect store at <https://www.mercedes-benz.ie/passengercars/being-an-owner/mercedes-me-connect.html>

## Comfort – connect to your car anytime, anywhere

Forgot to lock your car? With Remote Car Lock<sup>2</sup> you will receive a notification on your smartphone to let you know. With one tap, you can lock and unlock your vehicle so you never have to worry.

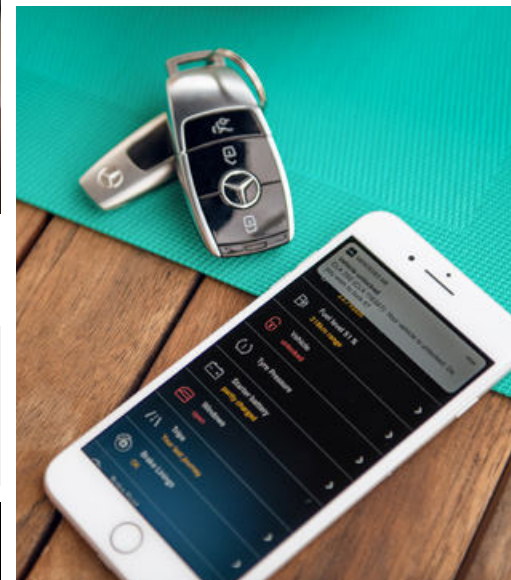

<sup>1</sup>Available on all models with the Vehicle Monitoring package. This option may vary between standard and additional cost dependent on the model

<sup>2</sup>Part of the Vehicle Status package. This option may vary between standard and additional cost dependent on the model

Images shown are for illustration purposes only



B-Class

---

Plug-in Hybrid

# Plug-in Hybrid Electric Vehicle (PHEV)

Our plug-in hybrid features a petrol powertrain, combined with a High Voltage battery and electric motor. Enjoy hybrid mode for maximum efficiency, or all-electric mode for emission-free driving.

## B 250 e

Petrol – 1,332 cc, 4-cylinder, 160 hp/118 kW

Electric motor – 102 hp/75 kW



# Plug-in Hybrid Electric Vehicle (PHEV) The B250 e.

Plug-in hybrid vehicles enjoy the same functionality of full Hybrid technology, with the added benefit that they can be charged from an external electricity source.

Available as:  
Progressive or AMG Line

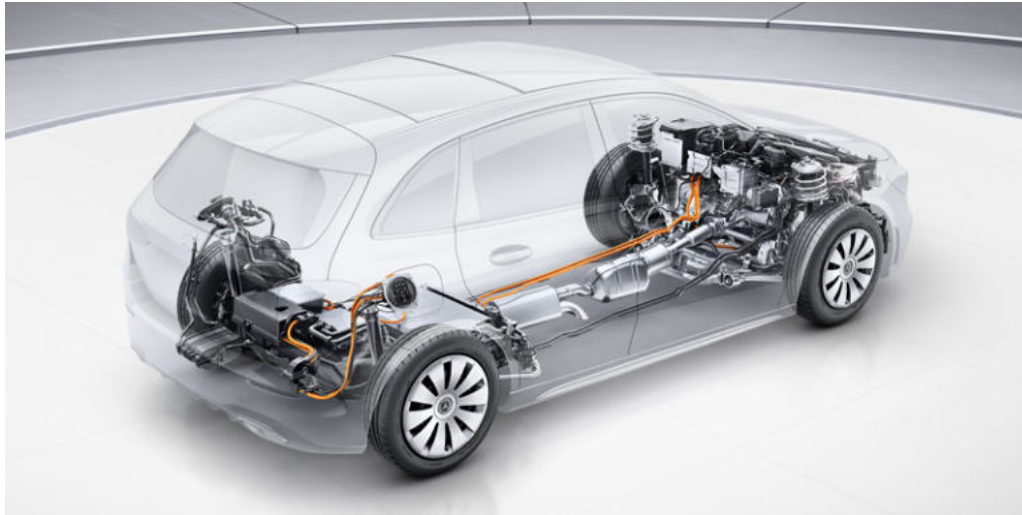

## Standard equipment

Advanced Plus Package featuring Ambient Interior Lighting, 10.25" Digital Instrument Cluster, Mirror Package & Smartphone Integration

Acoustic ambient protection – the tone pitch changes depending on the driving conditions. You can therefore also differentiate whether you are braking or accelerating. Above 30 kph, the system is basically deactivated since wind and tyre noise tend to dominate at higher speeds

Charging cable – Mode 2 cable (5 meters, straight), 3-pin plug, for household sockets up to 2.3 kW

Charging cable – Mode 3 cable (4 meters, straight) for wallbox and public charging stations

Charging socket

Charging system – AC charging system rated at 7.4kW

Comfort suspension

Pre-entry climate control

Radar-based recuperation

Remote and Charging Services Plus

## Technical details

|   |  |
|---|--|
| Equivalent All-Electric Range (EAER) <sup>1</sup> | 68–69 km   |
| AC charging time, 10–100% <sup>2</sup>            | 5 hrs 30 mins at a domestic socket <sup>3</sup><br>1 hr 45 mins / 3 hrs 15 mins at a wallbox |
| Range power consumption, combined <sup>1,4</sup>  | 15.4–14.7 kWh/100 km   |
| Battery type (usable)                             | lithium-ion (10.6 kWh)   |
| Capacity on-board charger                         | 7.4kW  |



1. The indicated values were determined according to the prescribed measurement method – Worldwide Harmonised Light Vehicle Test Procedure (WLTP). Figures shown may include options which are not available in Ireland. For Plug-in Hybrid Electric Vehicle (PHEV) figures determined with the battery fully charged, using a combination of both battery power and fuel. These models require mains electricity for charging. 2. Specified voltage and current values refer to network infrastructure and can be limited by the vehicle. Times are from 10–100% charge using a wallbox (three-phase) or standard socket (single-phase). 3. If you are planning to charge your Mercedes-Benz plug-in electric vehicle using a 3-pin domestic plug socket you must get a qualified electrician to inspect and sign off the socket to confirm it is safe and suitable to charge your vehicle. Do not use an electric vehicle 3-pin charge cable with an extension cord. 4. The certified electrical consumption is generally determined at maximum AC charging capacity using a Mode 3 cable. It is therefore recommended that vehicles with a HV battery preferably be charged at a wallbox or an AC charging station with a Mode 3 cable in order to achieve shorter charging times and improved charging efficiency.

< >

# B-Class Model lines overview

Progressive



AMG Line



# B-Class Progressive

Standard equipment highlights



## Engine, Transmission and Suspension

Driving modes - DYNAMIC SELECT with a choice of driving modes: Eco, Comfort, Sport and Individual

## Exterior

17" alloy wheels - 5-spoke design, aerodynamically optimised, painted matt black with a high-shine finish

Chrome weather strip

LED High Performance headlamps with integrated LED daytime running lights

Radiator grille in black with two louvres painted silver with chrome insert





### Interior

Comfort seats with adjustable head restraints – ensure good long-distance comfort and are extensively adjustable for length, height and the angle of the seat surface

EASY-PACK tailgate – can be opened and closed electrically

Heated front seats – seat heating quickly brings the seat cushions and backrests up to a pleasant temperature. Three levels of intensity can be selected

KEYLESS-GO starting function

Parking Package including Reverse Camera and Sensors in the front and rear bumper

Rear seats with folding and 40:20:40 split function

Speed-sensitive power steering

THERMATIC automatic climate control

### Communications, Safety and Assistance Systems

7-inch digital instrument display, 10.25-inch touchscreen media display

Active Brake Assist – forward collision warning system with autonomous braking intervention

ATTENTION ASSIST – monitors steering behaviour and can help alert you to long journey fatigue

MBUX multimedia system including DAB digital radio and touchpad

Mercedes me Remote Services

Multifunction sports steering wheel in leather, black topstitching and bezel in silver chrome

Speed Limit Assist – detects the speed limit and displays it in the instrument cluster

USB interface in oddments tray and two USB (type C) interfaces in centre console

### Trim and Upholstery

Spiral look



ARTICO man-made leather black



# B-Class AMG Line

Standard equipment highlights



In addition to/replacement of Progressive Line

#### Exterior

18" AMG alloy wheels – 5-twin-spoke design, aerodynamically optimised, painted in tremolite grey with a high-shine finish

AMG bodystyling, consisting of AMG front apron with front splitter, AMG side sill panels and AMG rear apron and visible exhaust tailpipes

Chrome-plated waistline and window line trim strips

Diamond radiator grille with pins in chrome

Lowered comfort suspension (not available for B 250E)







## Interior

AMG model floor mats

Door handles in galvanised silver

Pedals – AMG brushed stainless steel sports pedals with rubber studs

Sports seats – optimise lateral support for dynamic driving and at the same time provide comfort for everyday use

Steering wheel – 3-spoke, 12-button multifunction sports steering wheel in nappa leather with flattened bottom section and perforated grip area



## Trim and Upholstery

Carbon-structure trim



ARTICO man-made leather/  
DINAMICA microfibre in black with  
contrast stitching in red

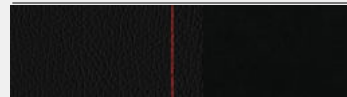

# Upholsteries

## Progressive



ARTICO man-made leather black (101)

Standard



ARTICO man-made leather macchiato beige / black (105)

Option



ARTICO man-made leather / Fléron fabric black (321A)

Option



Leather black (201)

Option (Requires Leather Package)



Leather macchiato beige / black (205)

Option (Requires Leather Package)

# Upholsteries

## AMG Line

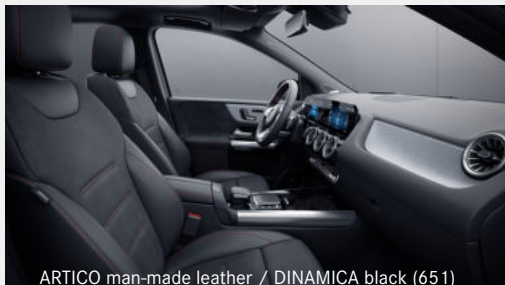

ARTICO man-made leather / DINAMICA black (651)

Standard



ARTICO man-made leather neva grey / black 159)

Option



Leather black (211)

Option (Requires Leather Package)

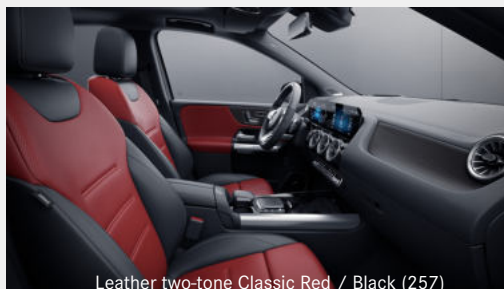

Leather two-tone Classic Red / Black (257)

Option (Requires AMG leather Package)



Leather two-tone titanium grey pearl / black (258)

Option (Requires AMG Leather Package)

# Trim options

## Progressive



Spiral-look trim elements (H60)

Standard



Brown open-pore walnut wood trim(H23)

Option



Light longitudinal-grain aluminium trim (H44)

Option



Black open-pore linden wood trim (H15)

Option

## AMG Line



Carbon-structure trim (H62)

Standard



Light longitudinal-grain aluminium trim (H44)

Option



Black open-pore linden wood trim (H15)

Option

# Wheel options

## Progressive



Standard (17-inch) 5-twin-spoke light-alloy wheels (R11)



No Cost Option (17-inch) 5-twin-spoke light-alloy wheels (R04)



No Cost Option (17-inch) 10-spoke light-alloy wheels (72R)



Optional (18-inch) 5-twin-spoke light-alloy wheels (01R)



Optional (18-inch) 5-twin-spoke light-alloy wheels (R31)

# Wheel options

## AMG Line



Standard (18-inch) AMG 5-twin-spoke light-alloy wheels (RQS)



Optional (18-inch) AMG 5-twin-spoke light-alloy wheels (RQT)



Optional (19-inch) AMG multi-spoke light-alloy wheels (RVG)



Optional (19-inch) AMG multi-spoke light-alloy wheels (RVK)

# Colour options

## Non-metallic



Night Black (696U) Standard



Polar White (149U) Option

## Metallic



Digital White (144U) Option



Cosmos Black (191U) Option



Iridium Silver (775U) Option



Mountain Grey (787U) Option



Denim Blue (667U) Option



Rosé Gold (817U) Option

## MANUFAKTUR



MANUFAKTUR Patagonia Red (993U) Option



MANUFAKTUR Mountain Grey MAGNO¹ (662U) Option

<sup>1</sup>magno matt paint finishes require extra care. Please refer to the Owner's Manual for instructions

Please note that, owing to limitations of on-screen representation, paint colours may differ from those shown

# Standard Equipment

- 17-inch Alloy Wheels
- 10.25-inch Media display
- Active Brake Assist
- Active Lane Keeping Assist
- Communications module (LTE) for the use of Mercedes me connect services
- Digital radio
- DYNAMIC SELECT
- EASY-PACK power tailgate
- Heated front seats
- LED High Performance headlamp
- MBUX multimedia system
- Parking Assist PARKTRONIC inc Reversing Camera + Parking Sensors
- Preinstallation for digital key transfer
- Preinstallation for Live Traffic Information
- Seat Comfort package
- Speed Limit Assist
- Stowage compartment in centre console with retractable cover
- Sun visor with illuminated vanity mirror
- THERMATIC automatic climate control
- Touchpad
- Velour floor mats
- Windscreen wipers with rain sensor

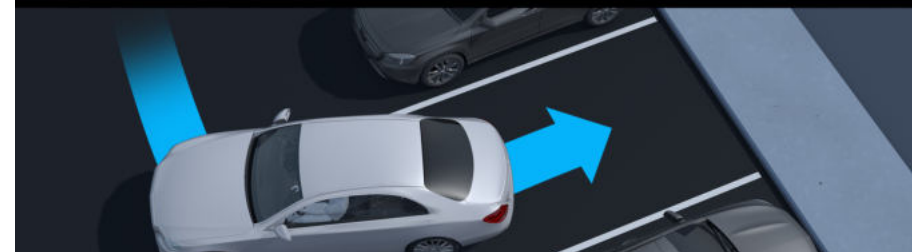
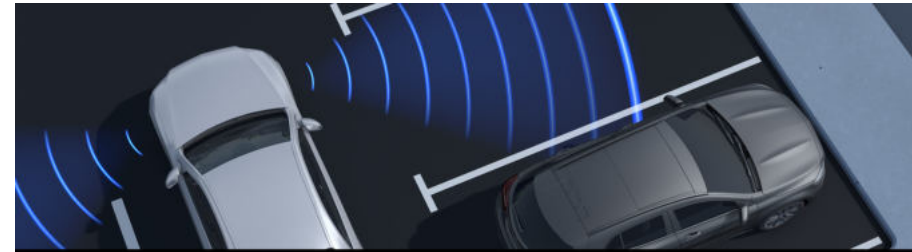

Owing to supply shortages, options for vehicles may be temporarily restricted, resulting in modified vehicle and/or package pricing. Regularly updated information on this issue is available from Mercedes-Benz dealers.



# Advanced Plus Package

From<sup>1</sup> €1,607 (Standard for PHEV)

- **Ambient Lighting in 64 Colours**

Showcase the interior according to your personal preferences or current mood. The 64 colours of the ambient lighting create fascinating colour schemes, for example in the illuminated air vents, doors or the dashboard.

- **Digital Instrument Display (10.25-inch):**

You experience the entire range of digital display possibilities. The large, high-resolution 10.25-inch display is individually configured by you – for example in the classic form, with the speedometer on the left and the rev counter on the right. Visually impressive and easy to read: travel and driving assistance information is superimposed using the full display area.

- **Mirror package:**

You can fold in the exterior mirrors electrically and thus make your car slimmer at the press of a button. Small parking spaces suddenly become big enough. Importantly, this also protects you from annoying damage. The driver's exterior mirror and the rear-view mirror are also able to register headlamp dazzle from the rear and dim automatically.



<sup>1</sup>Price and availability subject to vehicle specification

Owing to supply shortages, options for vehicles may be temporarily restricted, resulting in modified vehicle and/or package pricing. Regularly updated information on this issue is available from Mercedes-Benz dealers.

# Premium Package

From<sup>1</sup> €3,522

In addition to/replacement of Advanced Plus Package components

- **Illuminated Door Sills:**  
Even getting in and out becomes an experience in itself. As part of this, the high-quality stainless steel sill panels are illuminated with "Mercedes-Benz" lettering.
- **Hard-disc Navigation:**  
Save time thanks to fast hard-disc navigation with flexible options for entries via touch control or voice input
- **THERMOTRONIC:**  
The THERMOTRONIC controls the individual temperature in two zones. The activated charcoal filter works very efficiently, and as well as particulate matter it also eliminates harmful substances and unpleasant odours. Your health will thank you for it.



<sup>1</sup>Price and availability subject to vehicle specification

Owing to supply shortages, options for vehicles may be temporarily restricted, resulting in modified vehicle and/or package pricing. Regularly updated information on this issue is available from Mercedes-Benz dealers.

# Premium Plus Package From<sup>1</sup> €6,557

In addition to/replacement of Premium Package components

- **Head-up Display**

Ideal prospects for sporty driving fun and a superior driving experience: the head-up display transforms your windscreen into an exciting digital cockpit. This means you always have a direct view of key information. Your full attention remains on the road and the traffic conditions in front of you

- **MBUX Interior-Assist:**

Enjoy contactless ease of operation: this innovative system detects and interprets your hand and arm movements. This means you can activate selected functions in a matter of seconds. The system is able to differentiate between driver and front passenger – so that you reach precisely the menu you wish to use.

- **Parking Package with 360-degree camera:**

Park with peace of mind. The all-round visibility thanks to the 360 degree camera including a virtual birds-eye view is particularly impressive.

- **MULTIBEAM LED Headlights:**

For your perfect vision: the adaptive MULTIBEAM LED headlamps with individually controllable LEDs react to the traffic situation. Partial main beam omits other road users without dazzling them. And the cornering light and active light functions illuminate the field of vision optimally so that you can detect dangers sooner.



<sup>1</sup>Price and availability subject to vehicle specification

Owing to supply shortages, options for vehicles may be temporarily restricted, resulting in modified vehicle and/or package pricing. Regularly updated information on this issue is available from Mercedes-Benz dealers.

# Night Package From<sup>1</sup> €731

The Night Package adds further attractive features. Particularly eye-catching highlights in striking black or high-gloss black reinforce the individuality and sporty standards of your vehicle.

## Components of the Night package:

- (18-inch) 5-twin-spoke light-alloy wheels, painted in black with a high-sheen finish (01R), in conj. with Progressive
- (18-inch) AMG 5-twin-spoke light-alloy wheels, aerodynamically optimised, painted in black with a high-sheen finish (RQT), in conj. with AMG Line
- Radiator trim with twin louvre painted in high-gloss black and chrome insert, in conj. with Progressive line
- Diamond radiator grille with pins in chrome, individual louvre painted in black and chrome insert, in conj. with AMG Line
- Front apron with insert in high-gloss black, in conj. with Progressive line
- AMG front apron with insert in high-gloss black, in conj. with AMG Line
- Rear apron with trim painted in high-gloss black
- Exterior mirror housings painted in black
- Beltline trim strip and window line trim in high-gloss black
- Heat-insulating dark-tinted glass starting from the B-pillar



# Optional Equipment

Price<sup>1</sup>

|  |        |
|--|--------|
| Active Distance Assist DISTRONIC         | €975   |
| Adaptive Highbeam Assist                 | €291   |
| Dark tinted windows                      | €487   |
| Hard Disc Navigation                     | €892   |
| Heated Steering Wheel (Progressive Only) | €259   |
| Heated Windscreen Washer System          | €187   |
| Load compartment Package                 | €244   |
| Metallic Paint                           | €1,022 |
| Panoramic Sunroof                        | €1,948 |
| Partition Net                            | €244   |
| Smartphone Integration                   | €487   |
| Traffic Sign Assist                      | €480   |
| Trailer Coupling with ESP                | €1,299 |
| Urban Guard                              | €714   |
| Urban Guard Plus                         | €1,040 |



<sup>1</sup>Price and availability subject to vehicle specification

Owing to supply shortages, options for vehicles may be temporarily restricted, resulting in modified vehicle and/or package pricing. Regularly updated information on this issue is available from Mercedes-Benz dealers.

# Technical data

| Model   | B 180           | B 200           | B 250e                     | B 180d          | B 200d           | B 220d          |
|---|-----------------|-----------------|----------------------------|-----------------|------------------|-----------------|
| <b>Engine</b>   |                 |                 |                            |                 |                  |                 |
| Fuel delivery   | Petrol          | Petrol          | Petrol                     | Diesel          | Diesel           | Diesel          |
| Total displacement cc                                       | 1,332           | 1,332           | 1,332                      | 1,950           | 1,950            | 1,950           |
| Arrangement/cylinders/valves                                | in-line/4/16    | in-line/4/16    | in-line/4/16               | in-line/4/16    | in-line/4/16     | in-line/4/16    |
| Power <sup>1</sup> hp (kW) at rpm                           |                 |                 |                            |                 |                  |                 |
| Combustion engine   | 136 (100)/5,500 | 163 (120)/5,500 | 160 (118)/5,500            | 116 (85)/3,400  | 150 (110)/3,400- | 190 (140)/3,800 |
| Electric motor  | -               | -               | 102 (75)/2,500             | -               | 4,400 -          | -               |
| System output   | -               | -               | 218 (160)                  | -               | -                | -               |
| Torque <sup>1</sup> Nm at rpm                               |                 |                 |                            |                 |                  |                 |
| Combustion engine   | 200/1,460-4,000 | 250/1,620-4,000 | 250/1,620-4,000            | 280/1,300-2,600 | 320/1,400-3,200  | 400/1,600-2,600 |
| Electric motor  | -               | -               | 300/2,000                  | -               | -                | -               |
| System output   | -               | -               | 450                        | -               | -                | -               |
| Compression ratio   | 10.6:1          | 10.6:1          | 10.6:1                     | 15.5:1          | 15.5:1           | 15.5:1          |
| Equivalent All-Electric Range (EAER) <sup>2</sup> km        | -               | -               | 41-42                      | -               | -                | -               |
| Battery type (usable) kWh                                   | -               | -               | Lithium-ion/10.6           | -               | -                | -               |
| Range power consumption, combined <sup>2,3</sup> kWh/100 km | -               | -               | 15.4-14.7                  | -               | -                | -               |
| AC charging time, 10-100% <sup>4</sup>                      |                 |                 |                            |                 |                  |                 |
| At a domestic socket <sup>5</sup>                           | -               | -               | 5 hrs 30 mins              | -               | -                | -               |
| At a wallbox  | -               | -               | 1 hr 45 mins/3 hrs 15 mins | -               | -                | -               |
| Capacity on-board charger kW                                | -               | -               | 10.9                       | -               | -                | -               |
| Emissions standard  | EURO 6D-ISC-FCM | EURO 6D-ISC-FCM | EURO 6D-ISC-FCM            | EURO 6D-ISC-FCM | EURO 6D-ISC-FCM  | EURO 6D-ISC-FCM |

<sup>1</sup>Figures according to Directive 80/11269/EEC in the currently applicable version. <sup>2</sup>The indicated values were determined according to the prescribed measurement method - Worldwide Harmonised Light Vehicle Test Procedure (WLTP). Figures shown may include options which are not available in Ireland. For Plug-in Hybrid Electric Vehicle (PHEV) figures determined with the battery fully charged, using a combination of both battery power and fuel. These models require mains electricity for charging. <sup>3</sup>The certified electrical consumption is generally determined at maximum AC charging capacity using a Mode 3 cable. It is therefore recommended that vehicles with a HV battery preferably be charged at a wallbox or an AC charging station with a Mode 3 cable in order to achieve shorter charging times and improved charging efficiency. <sup>4</sup>Specified voltage and current values refer to network infrastructure and can be limited by the vehicle. Times are from 10-100% charge using a wallbox (three-phase) or standard socket (single-phase) <sup>5</sup>If you are planning to charge your Mercedes-Benz plug-in electric vehicle using a 3-pin domestic plug socket you must get a qualified electrician to inspect and sign off the socket to confirm it is safe and suitable to charge your vehicle. Do not use an electric vehicle 3-pin charge cable with an extension cord

# Technical data

● Standard – Not available

| Model   |          | B 180   | B 200   | B 250e             | B 180d  | B 200d | B 220d  |
|---|----------|---------|---------|--------------------|---------|--------|---------|
| <b>Transmission</b>   |          |         |         |                    |         |        |         |
| 7G-DCT 7-speed automatic                                      |          | ●       | ●       | –                  | –       | –      | –       |
| 8G-DCT 8-speed automatic                                      |          | –       | –       | ●                  | ●       | ●      | ●       |
| <b>Performance</b>  |          |         |         |                    |         |        |         |
| Acceleration 0–100 kph  | sec      | 9.0     | 8.2     | 6.8                | 9.8     | 8.3    | 7.2     |
| Top speed (electric mode)                                     | kph      | 212     | 224     | 235 (140)          | 200     | 220    | 234     |
| <b>Weights and capacities</b>                                 |          |         |         |                    |         |        |         |
| Kerb weight <sup>6</sup>                                      | kg       | 1,405   | 1,410   | 1,725              | 1,535   | 1,535  | 1,565   |
| Perm. Gross Vehicle Weight                                    | kg       | 1,955   | 1,960   | 2,255              | 2,075   | 2,075  | 2,080   |
| Boot capacity – seats up                                      |          | 455     | 455     | 405                | 445     | 445    | 445     |
| seats down  | l        | 1,540   | 1,540   | 1,440              | 1,530   | 1,530  | 1,530   |
| Towing capacity – unbraked                                    |          | 700     | 705     | 750                | 750     | 750    | 750     |
| braked  | kg       | 1,400   | 1,600   | 1,600 <sup>7</sup> | 1,400   | 1,600  | 1,600   |
| Fuel tank capacity/of which reserve                           | l        | 43/5    | 43/5    | 35/5               | 43/5    | 43/5   | 51/5    |
| Turning circle  | m        | 11.00   | 11.00   | 11.00              | 11.00   | 11.00  | 11.00   |
| <b>Fuel consumption<sup>8,9,10</sup></b>                      |          |         |         |                    |         |        |         |
| Combined (consumption dependent on chosen optional equipment) | l/100 km | 6.2–6.1 | 6.2–6.1 | 6.6–6.5            | 5.3–5.2 | 5.1    | 5.2–5.1 |

<sup>6</sup>Mass of the vehicle in running order with at least 90% full fuel tank, plus the mass of the driver (estimated by law at 75 kg), fuel and fluids, equipped with the standard equipment as specified by the manufacturer as well as, where applicable, the mass of the body, cab, trailer coupling and spare wheel(s) as well as tools. Optional extras, additional equipment and accessories can influence the weight, residual payload, rolling resistance, aerodynamics, etc., and therefore also affect the consumption/CO<sub>2</sub> values <sup>7</sup>Please note there is currently no availability to retrofit a tow bar for GLA 250 e <sup>8</sup>All figures are based on a standard specification with the smallest tyre size <sup>9</sup>The choice of wheels and transmission may affect CO<sub>2</sub> emissions and corresponding VRT band. <sup>10</sup> The indicated values were determined according to the prescribed measurement method – Worldwide Harmonised Light Vehicle Test Procedure (WLTP). Figures shown may include options which are not available in Ireland.

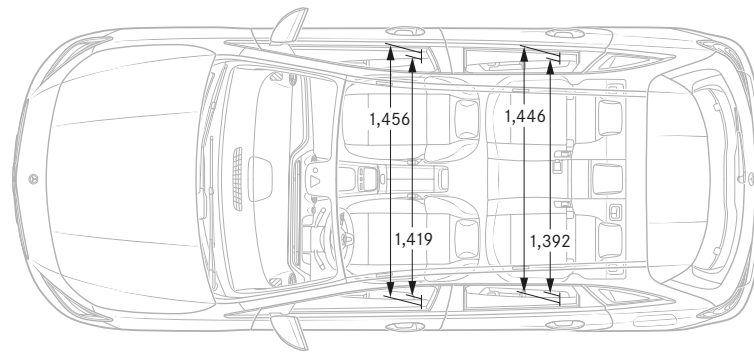
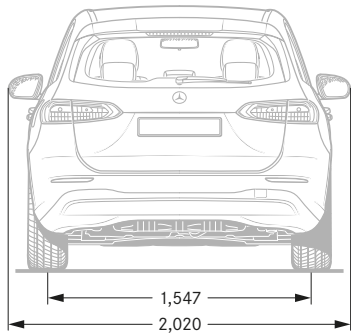
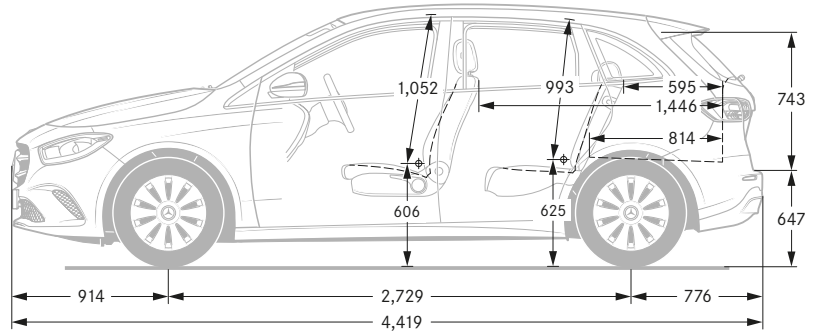
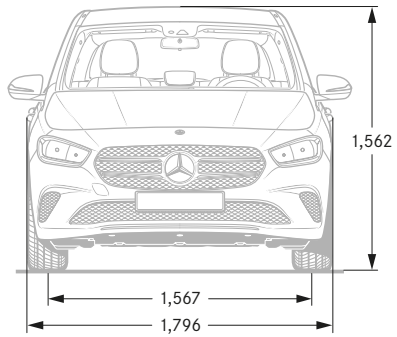



## Boot capacity (PHEV)



1 Open luggage compartment behind rear seat, loaded to upper edge of rear seat backrest, volume 405 litres (V 211-2)



2 Open luggage compartment behind rear seat, loaded to roof, volume 515 litres (V 214-2)

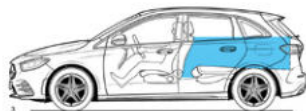

3 Open luggage compartment behind driver's seat, rear seat backrest folded, loaded to upper edge of driver's backrest, volume 1,030 litres (V 211-1)

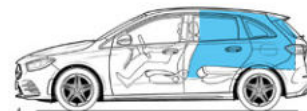

4 Open luggage compartment behind driver's seat, rear seat backrest folded, loaded to roof, volume 1,440 litres (V 214-1)



5 Largest cuboid: Dimensions 1,275 × 936 × 652 mm, volume 778 litres

## Boot capacity (combustion)



1 Open luggage compartment behind rear seat, loaded to upper edge of rear seat backrest, volume 440 litres (V 211-2)



2 Open luggage compartment behind rear seat, loaded to roof, volume 575 litres (V 214-2)

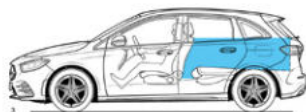

3 Open luggage compartment behind driver's seat, rear seat backrest folded, loaded to upper edge of driver's backrest, volume 1,100 litres (V 211-1)

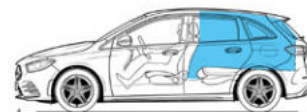

4 Open luggage compartment behind driver's seat, rear seat backrest folded, loaded to roof, volume 1,525 litres (V 214-1)



5 Largest cuboid: Dimensions 1,275 × 936 × 652 mm, volume 778 litres



# Mercedes me

Welcome to your Mercedes-Benz world.

Imagine if ...you could connect with your Mercedes-Benz? With Mercedes me connect, you can! Mercedes me connect offers you new connectivity services that make driving more comfortable and incorporates your car into your personal lifestyle.

## Standard Services

- Maintenance Management
- Telediagnosics
- Breakdown Management
- Accident Recovery
- Mercedes-Benz Emergency Call System

## Remote Online Services<sup>1</sup>

- Remote Retrieval of Vehicle Status (fuel level, tyre pressure etc.)
- Parked Vehicle Locator
- Vehicle Tracker
- Geofencing
- Door lock / unlock function

<sup>1</sup> Can be used with Remote Online special feature.





Getting connected is easy. Just set up your Mercedes me account and get in touch with your Mercedes-Benz dealer to connect your vehicle to your profile to access your Mercedes me connect services.

Contact your dealer to get connected, or go to [www.mercedes.me](http://www.mercedes.me) for more details.

Follow us on the following social media channels:

 [facebook.com/MercedesBenzIreland](https://facebook.com/MercedesBenzIreland)

 [instagram.com/mercedesbenz\\_ireland](https://instagram.com/mercedesbenz_ireland)

 [linkedin.com/company/motor distributors ltd](https://linkedin.com/company/motor-distributors-ltd)

 [twitter.com/MB\\_IRELAND](https://twitter.com/MB_IRELAND)

 [youtube.com/mercedesbenzireland](https://youtube.com/mercedesbenzireland)

 [pinterest.com/mercedesbenzire](https://pinterest.com/mercedesbenzire)

Motor Distributors Ltd.  
Naas Road  
Dublin 12  
Ireland  
[www.mercedes-benz.ie](http://www.mercedes-benz.ie)

Information correct at time of going to print. Prices and specifications are subject to change without prior notice. Prices quoted do not include dealer and delivery related charges. Images are for illustrative purposes only, actual product may vary. For more specific information in relation to the range of models, features, optional extras, colours and services available please speak to your local authorised Mercedes-Benz dealer.